

DRG. No.
 DRG. REF.

CUSTOMER		
ORDER No.		
PART No.		
OUR ORDER No.		
FRAME SIZE		
KW.	RPM.	
Hz	PHASE	
VOLTS	POLES	
BRGS.	DE.	NDE.
MOTOR NETT WT.		Kg.
SPECIAL REMARKS		

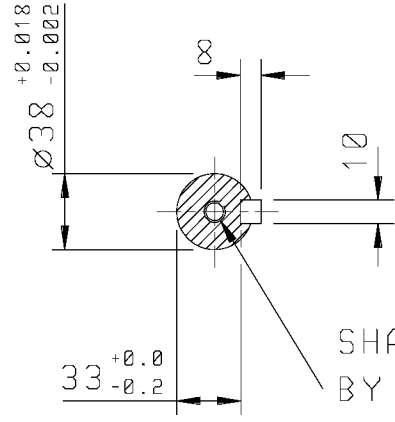

SHAFT TAPPED M12
 BY 28 DEEP
 TO DIN 332 FORM 'D'

CABLE ENTRY POSITION SHOWN IS FOR ILLUSTRATION ONLY, TERMINAL BOX CAN BE ROTATED THROUGH 90° INTERVALS.

DRIP-PROOF COWL FITTED ON ALL VERTICAL SHAFT DOWN MOTORS & ALL MOTORS WITH CAST IRON FAN COVERS, OR WHEN REQUESTED.

SECTION ON 'X'

4-HOLES TAPPED BLIND M10, EQUALLY SPACED ON A 165 P.C.D

EXTERNAL EARTH POSITION

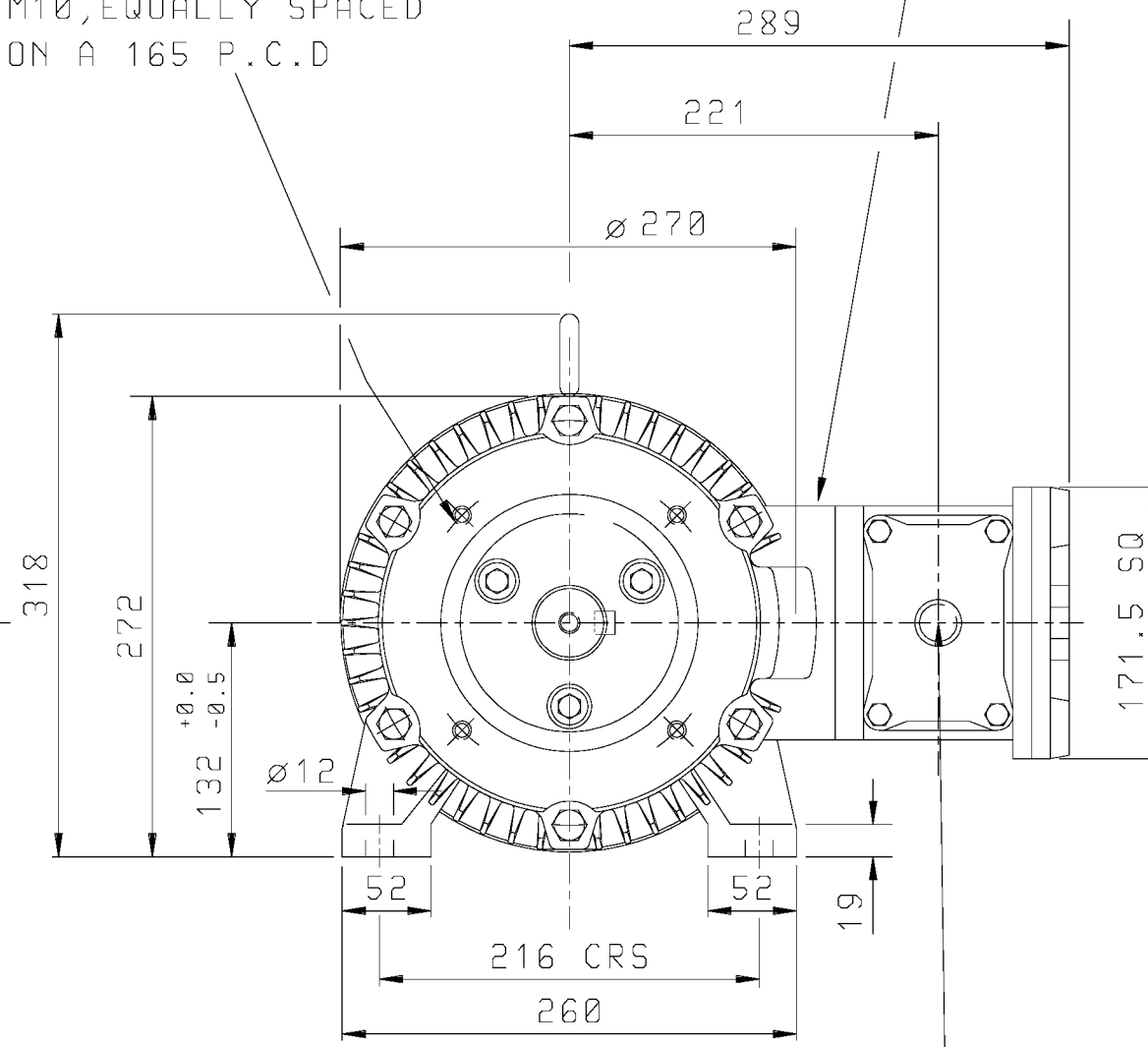
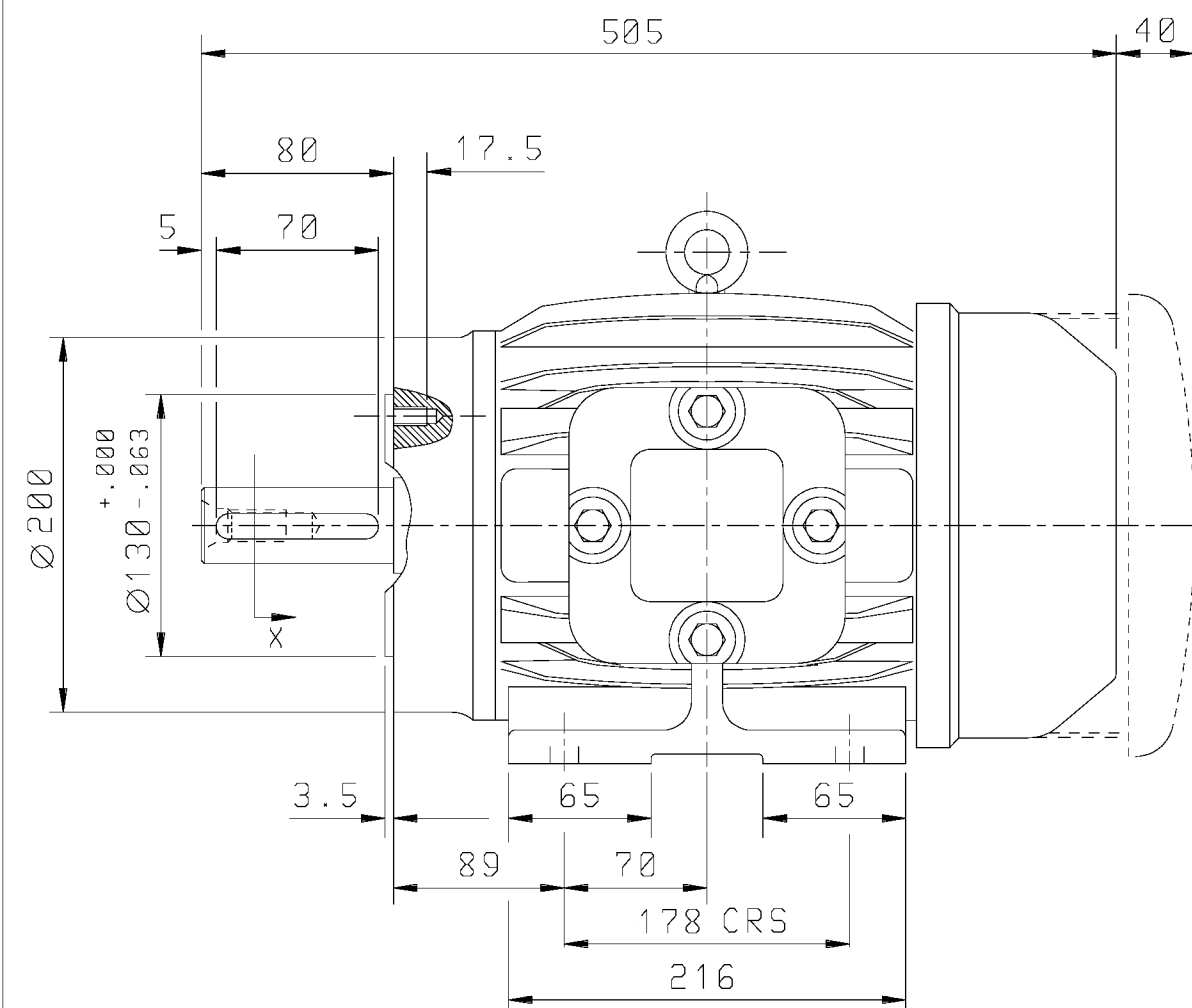

1 - CONDUIT ENTRY TAPPED M25 TO SUIT COMPRESSION GLAND

ALL DIMENSIONS IN MILLIMETRES

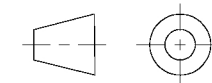

FIRST ANGLE PROJECTION

BROOK CROMPTON

Huddersfield, HD1 3LJ
 ENGLAND

SHEET SIZE

A3

TITLE

OUTLINE DIMENSION DRAWING 'W' FLAMEPROOF TOTALLY ENCLOSED FAN COOLED EEXD 132M FRAME FOOT & C FACE MOUNTED MOTOR GROUPS IIA & IIB

	NAME	DATE
DRAWN	ULS	26-11-03
CHECKED	DH	26-11-03
SCALE	N.T.S	

DRG. No.

DRG. REF.

REVISION:		DATE
-----------	--	------